

3D DRAWING



NOTES

1. BURR OF BRACKET SHOULD BE MINIMIZED.
2. BRACKET SHOULD BE FREE OF SHARP EDGES.
3. UNSPECIFIED RADIUS WOULD BE 0.5MM.
4. IMPORTANT PARTS ARE MARKED BY ASTERISK.
5. SAMPLE APPROVAL IS REQUIRED.

INFORMATION

ITEM NO.	K133 - 20
DESCRIPTION	NEO TENSION LOCK
MATERIAL	ALU6061 - T6, T = 4MM
WEIGHT	7.00g
DATE	16/JUL/2024

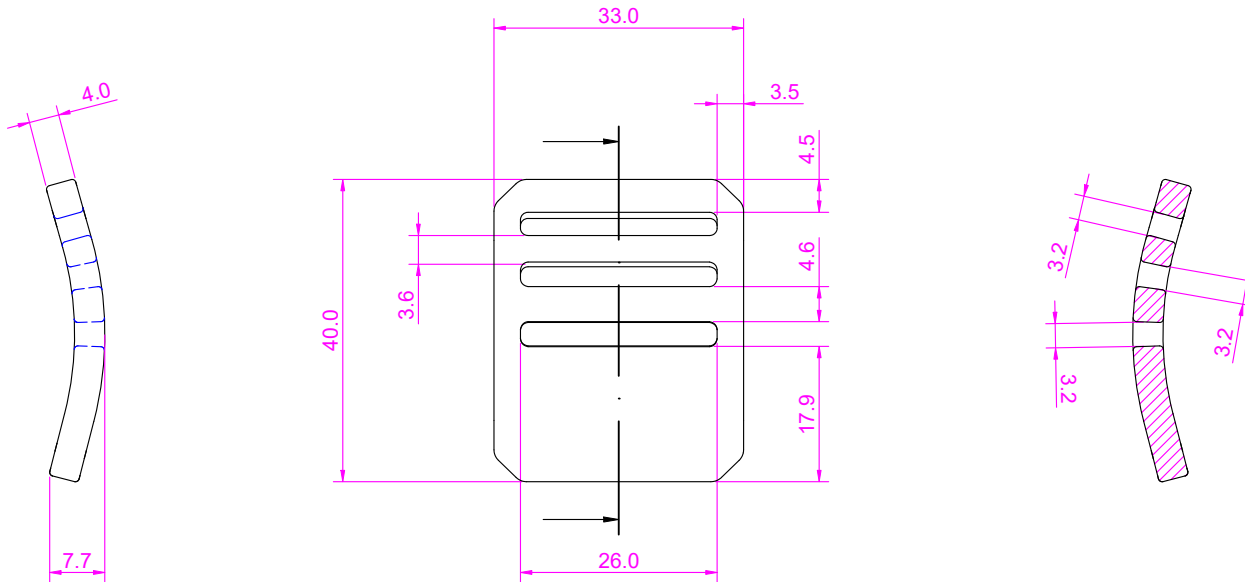

3D DRAWING



NOTES

1. BURR OF BRACKET SHOULD BE MINIMIZED.
2. BRACKET SHOULD BE FREE OF SHARP EDGES.
3. UNSPECIFIED RADIUS WOULD BE 0.5MM.
4. IMPORTANT PARTS ARE MARKED BY ASTERISK.
5. SAMPLE APPROVAL IS REQUIRED.

INFORMATION

ITEM NO.	K133 - 25
DESCRIPTION	NEO TENSION LOCK
MATERIAL	ALU6061 - T6, T = 4MM
WEIGHT	10.50g
DATE	16/JUL/2024